

Sürgülü Vana (Class 150/300/600) / Gate Valve (Class 150/300/600)

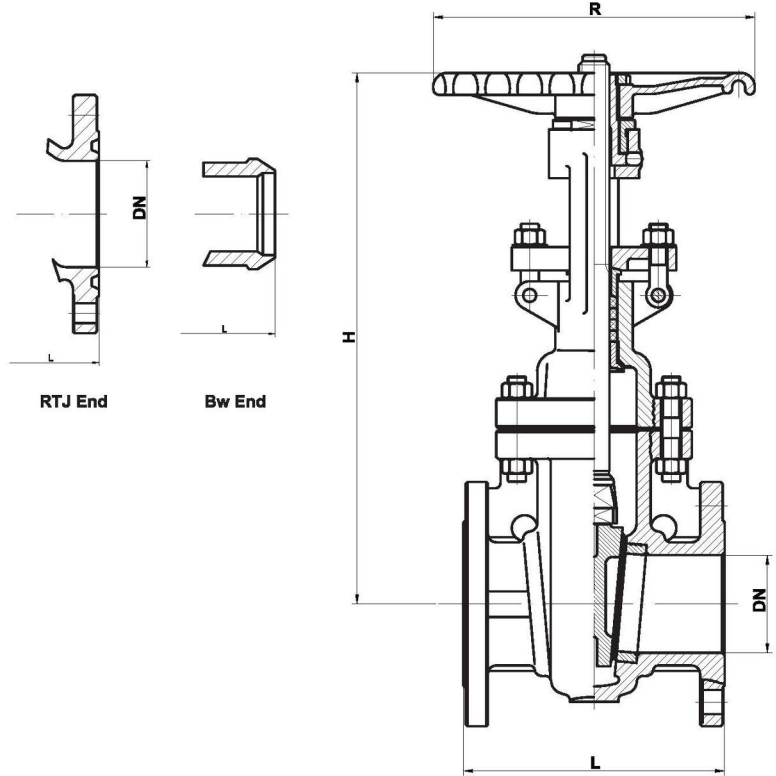

NO	PARÇA ADI	PART NAME	MATERIAL
1	GÖVDE	BODY	ASTM A216 WCB
2	SİT	SEAT RING	ASTM A105+13Cr
3	SÜRGÜ	WEDGE	ASTM A216+wcb+13Cr
4	MİL	STEM	ASTM A182 F6a
5	CONTA	GASKET	AISI 304+GRAPHITE
6	KAPAK	BONNET	ASTM A216 WCB
7	KAPAK ÇİVATASI	BONNET BOLT	ASTM A193 B7
8	KAPAK SOMUNU	BONNET NUT	ASTM A194 2H
9	ALT SİT BURCU	BACK SEAT BUSHING	ASTM A182 F6a
10	SALMASTRA	PACKING	GRAPHITE
11	GLEN	GLAND	STM A182 F6a
12	GLEN FLANŞI	GLAND FLANGE	ASTM A216 WCB
13	GLEN ÇİVATASI	GLAND EYEBOLT	STM A193 B7
14	GLEN SOMUNU	GLAND NUT	ASTM A194 2H
15	MİL SOMUNU	STEM NUT	ZCuAl10Fe3
16	HENDİL	HANDWHEEL	DUCTILE IRON
17	HENDİL SOMUNU	HANDWHEEL NUT	AISI 1020

Class	DN	H	R	L			KG
				RF	RTJ	BW	
150	15	195	120	108	119	108	4
	20	210	120	117	130	117	5
	25	240	140	127	140	127	7
	32	300	180	140	153	140	10
	40	395	200	165	178	165	14
	50	400	200	178	191	216	19
	65	435	200	191	203	241	25
	80	515	250	203	216	283	33
	100	595	280	229	241	305	49
	125	725	280	254	267	381	62
	150	780	300	267	279	403	77
	200	975	350	292	305	419	123
	250	1150	400	330	343	457	188
	300	1380	450	356	368	502	268
350	1545	500	381	394	572	385	
400	1733	500	406	419	610	500	
450	1915	500	432	445	680	601	
500	2122	600	457	470	711	764	
600	2520	600	508	521	813	1007	
650	-	-	559	-	864	-	
700	-	-	610	-	914	-	
750	-	-	610	-	914	-	
800	-	-	711	-	965	-	
850	-	-	762	-	1016	-	
900	-	-	711	-	1016	-	

Class	DN	H	R	L			KG
				RF	RTJ	BW	
300	15	198	120	140	151	140	6
	20	215	140	152	165	152	7
	25	245	160	165	178	165	10
	32	306	180	178	191	178	15
	40	400	200	190	203	190	21
	50	420	200	216	232	216	25
	65	446	200	241	257	241	30
	80	537	250	283	298	283	48
	100	619	280	305	321	305	73
	125	722	300	381	397	381	99
	150	806	350	403	419	403	130
	200	1000	400	419	435	419	208
	250	1240	450	457	473	457	334
	300	1425	500	502	518	502	450
350	1585	600	762	778	762	704	
400	1790	500	838	854	838	923	
450	1960	650	914	930	914	1131	
500	2158	750	991	1010	991	1345	
600	2576	900	1143	1165	1143	2122	
650	-	-	1245	1270	1245	-	
700	-	-	1346	1372	1346	-	
750	-	-	1397	1422	1397	-	
800	-	-	1524	1553	1524	-	
850	-	-	1626	1654	1626	-	
900	-	-	1727	1756	1757	-	
600	50	444	200	292	295	292	32
	65	500	250	330	333	330	52
	80	558	280	356	359	356	60
	100	665	300	432	435	432	107
	125	780	350	508	511	508	175
	150	868	450	559	562	559	216
	200	1073	500	660	664	660	399
	250	1263	650	787	791	787	605
	300	1600	700	838	841	838	851
	350	1705	900	889	892	889	1177
	400	1835	900	991	994	991	1513
	450	-	-	1092	1095	1092	-
	500	-	-	1194	1200	1194	-
	600	-	-	1397	1407	1397	-

UYGULAMA ALANLARI / APPLICATIONS

SICAK SU , SOĞUK SU , BUHAR , KİMYASAL AKIŞKANLAR , YAĞ , DOĞALGAZ , PETROL , ISITMA-SOĞUTMA HAVALANDIRMA / HOT-COLD WATER , STEAM , CHEMICAL FLUIDS , OIL , NATURAL GAS , HVAC ETC.

BAĞLANTILAR / ENDS : ANSI B16.5
ALINDAN ALINA / FACE TO FACE: ANSI B16.10